

Triton | Flush Bonded Window | HWT

STAINLESS STEEL HINGED, LATCHED DOWN COVER, WINDOW



CONSTRUCTION

Material (Box & Cover)	Hot Compression Molded Fiberglass Reinforced Polyester (Thermoset)
Gasket	Poured polyurethane seamless gasket
Window	Acrylic - Super Abrasion Resistant (SAR)
Back Panel Screw Size	#3/8-16 x 1/2 Hex Bolt
Hinge and Latch Hardware	304 Stainless Steel
Soft Edge Design	Rounded Edges, Minimal Protrusions Or Exposed Pocket Areas

INDUSTRY STANDARDS

UL/cUL File #	E64358
NEMA Ratings (UL508A, UL50 & UL50e)	1, 3, 3R, 4X, 12
CSA Std. C22.2 File #	LR069014
UL 1741 File #	E333478
Temperature Range	(-76°F to +274°F) (-60°C to +134°C)
Flammability Rating	UL94-5V
Window Temperature Range	(-26°F to +170°F) (-32°C to +76°C)
Window Flammability Rating	UL94-HB
Self Extinguishing	Non-Halogenated, Non-flame propagating
NFPA No. 101 Flame Spread	Class A (1)
Impact Rating	IK10
Certifications	UL, CSA, CE, REACH, RoHS
Outdoor UV Exposure (UL 746C)	(f1) Rated
Chemical Resistance	See chart on page 120

ACCESSORIES

BACK PANELS

Aluminum	BPT__A	pg. 108
Carbon Steel	BPT__CS	pg. 108

ACCESSORIES

4X Breather Vent	pg. 102
4X Drain Vent	pg. 102
PluggIt	pg. 103
Thermal Accessories	pg. 115
All Other Accessories	Pg. 102-117

MODIFICATIONS

Custom Colors	pg. 10-11
Silk Screening	pg. 10-11
EMI/RFI Shielding	pg. 10-11
Custom Window	pg. 10-11
Custom Cutouts/Holes	pg. 10-11

Triton | Flush Bonded Window | HWT

TECHNICAL DRAWINGS / DIMENSIONS

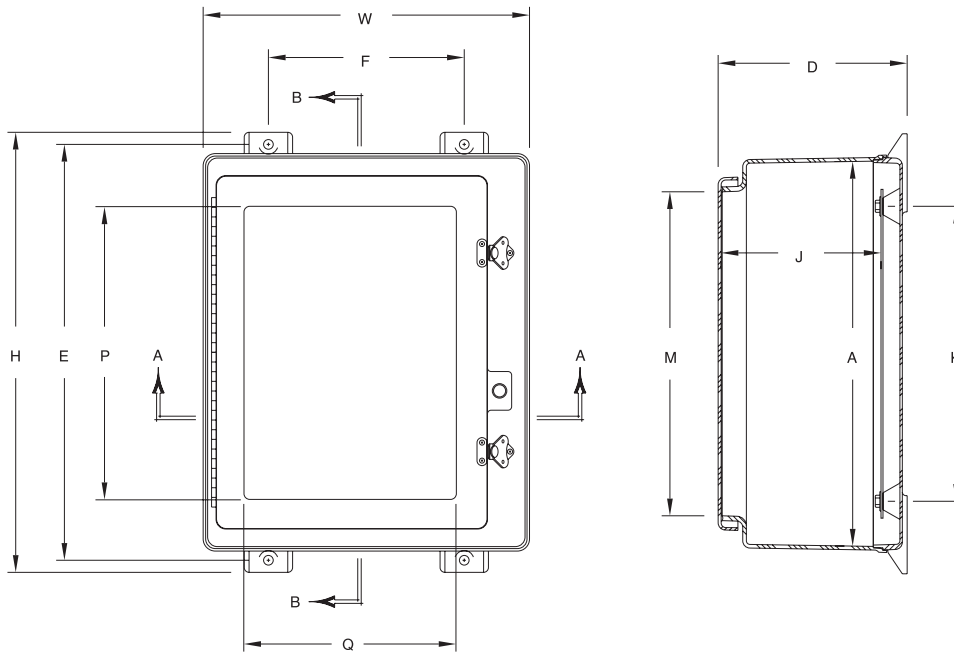

TRITON SERIES WINDOW ENCLOSURES

SIZE ID NUMBER	OVERALL H X W X D	INSIDE A X B X C	WINDOW AREA (MAXIMUM) P X Q	MOUNTING E X F	J	K	L	ENCLOSURE OPENING M X N	NO. OF LATCHES	SHIPPING WEIGHT	PANEL NUMBER
TW24208HWT	27.00 x 21.24 x 9.90 (686 x 539 x 252)	24.05 x 20.39 x 9.25 (611 x 518 x 235)	19 x 14 (483 x 356)	25.75 x 14.00 (654 x 356)	8.25 (209)	19.25 (489)	15.25 (387)	21.25 x 16.00 (540 x 406)	4	34 lbs.	BPT2420*
TW242410HWT	27.00 x 25.24 x 11.90 (686 x 641 x 302)	24.05 x 24.39 x 11.25 (611 x 619 x 286)	19 x 18 (483 x 457)	25.75 x 17.87 (654 x 454)	10.25 (260)	19.25 (489)	19.25 (489)	21.25 x 20.00 (540 x 508)	4	45 lbs.	BPT2424*
TW30208HWT	32.86 x 20.99 x 9.89 (835 x 533 x 251)	29.90 x 20.14 x 9.23 (760 x 511 x 234)	24 x 14 (610 x 356)	31.75 x 14.25 (806 x 362)	8.23 (209)	25.25 (641)	15.25 (387)	27.00 x 16.50 (686 x 419)	5	39 lbs.	BPT3020*
TW302410HWT	33.41 x 26.32 x 11.95 (849 x 668 x 304)	30.46 x 25.47 x 11.27 (774 x 647 x 286)	25 x 19 (635 x 483)	32.25 x 18.50 (819 x 470)	10.27 (261)	25.25 (641)	19.25 (489)	27.38 x 21.25 (695 x 540)	5	54 lbs.	BPT3024*
TW363012HWT	39.31 x 32.50 x 14.05 (999 x 826 x 357)	36.31 x 31.69 x 13.36 (922 x 805 x 339)	31 x 25 (787 x 635)	38.13 x 23.88 (968 x 606)	12.36 (314)	31.25 (794)	25.25 (641)	33.25 x 27.25 (845 x 692)	5	86 lbs.	BPT3630*
TW483612HWT	51.29 x 36.62 x 13.93 (1303 x 930 x 354)	48.33 x 36.22 x 13.25 (1228 x 920 x 336)	43 x 30 (1092 x 762)	50.12 x 28.5 (1273 x 724)	12.25 (311)	21.63 (549)	31.25 (794)	45.25 x 32.00 (1149 x 813)	10	99.8 lbs.	BPT4836*

All measures are in inches, items in parentheses are in millimeters
*Panel ordered separately.